

Vapor-Phase Cutting of Carbon Nanotubes Using a Nanomanipulator Platform

MS&T'10, October 18, 2010

Vladimir Mancevski, President and CTO, Xidex Corporation

Philip D. Rack, Professor, The University of Tennessee at Knoxville

Xidex Corporation

8906 Wall St., Suite 703, Austin, TX 78754

www.xidex.com

Outline

- Motivation for Vapor Phase Cutting of CNTs
- Electron Beam and Gas Precursor Parameters
- Precise, Site-Selective CNT Etching
- CNT Etching Efficiency
- CNT Etching in a Non-Environmental SEM
- Nanomanipulator-based gas delivery system

Motivation for Vapor-Phase Cutting of CNTs

- Damage-free, site-selective etching is needed for fabrication and repair in emerging CNT applications.
- Vapor-phase cutting has better resolution than laser ablative etching and mechanical abrasion with a microtip.
- Avoids gallium implantation, associated with FIB, which can change material properties.
- Avoids charging inherent to ion-solid interaction, which can lead to “riverbed effects.”
- Can be implemented in a non-environmental SEM, based on our new results.

Electron Beam Stimulated Deposition and Etching

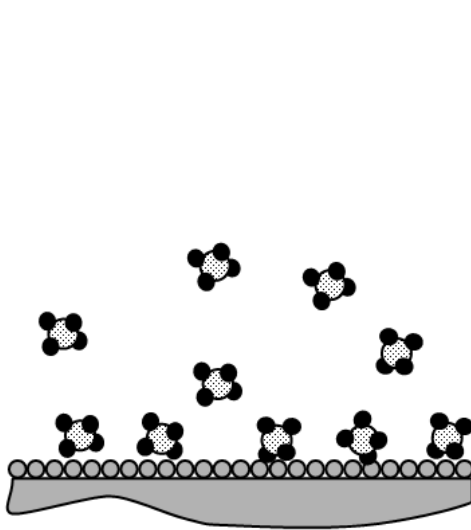

No E-Beam

Substrate and precursor gas without electron beam.

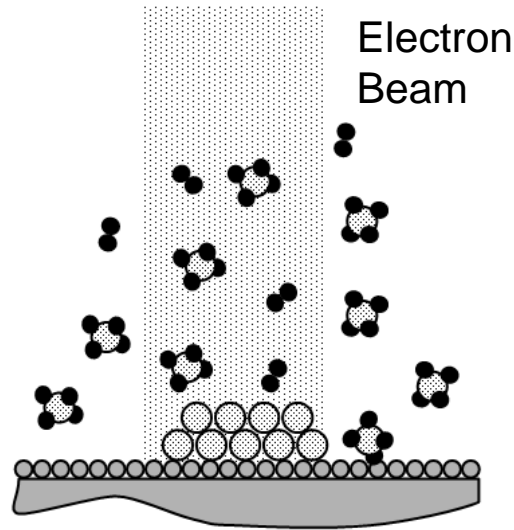

E-Beam Deposition

Precursor gas is dissociated, leaving behind condensed material.

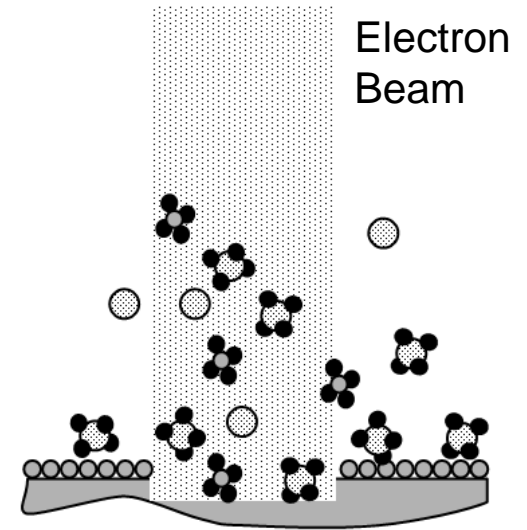

E-beam etching

Dissociated species react with substrate material, forming volatile species which desorb from the substrate surface.

Xidex

NANODEVICES AT WORK

Mass Transport of Precursor

Mass transport of precursor species is controlled by localized partial pressure, temperature, and desorption activation energy of precursor.

Surface density of adsorbed species (N_a)	$N_a = \tau_a \Gamma_{mol} \left(\frac{\text{molecules}}{m^2} \right)$
Molecular flux (Γ_{mol})	$\Gamma_{mol} = \frac{P}{\sqrt{2\pi mkT}} \left(\frac{\text{molecules}}{s \cdot m^2} \right)$
Mean stay time (τ_a)	$\tau_a = \frac{1}{\nu} \exp\left(\frac{E_{des}}{kT}\right) (s)$

P :	molecular partial pressure
m :	molecular mass,
k :	Boltzmann's constant
T :	absolute temperature
ν :	Attempt frequency (typically related to vibrational energy of adsorbed species)
E_{des} :	desorption energy of adsorbed molecule

Xidex

NANODEVICES AT WORK

Dissociation Rate of Precursor

The reaction rate is a function of both the beam energy (σ) and the current density (Γ_e).

Dissociation rate (k_e)

$$k_e = \sigma \Gamma_e \left(\frac{\text{reactions}}{s} \right)$$

σ : electron beam stimulated dissociation cross-section
 Γ_e : electron flux

Electron flux is simply dependent on the electron beam current density.

Electron beam stimulated dissociation cross-section is a function of the electron beam energy.

These cross-sections are characterized by low energy threshold energy, a peak maximum at tens to hundreds of electron volts (eV) and a continual decline with increasing beam energy past the peak maximum.

Xidex

NANODEVICES AT WORK

Beam Energy

Lower primary electron beam energies and higher currents increase the CNT etch rate in a reaction rate limited process.

Lower primary electron beam energies increase the dissociation cross-section for the precursor and typically increase the secondary electron yield which also contribute to the electron beam induced etching process.

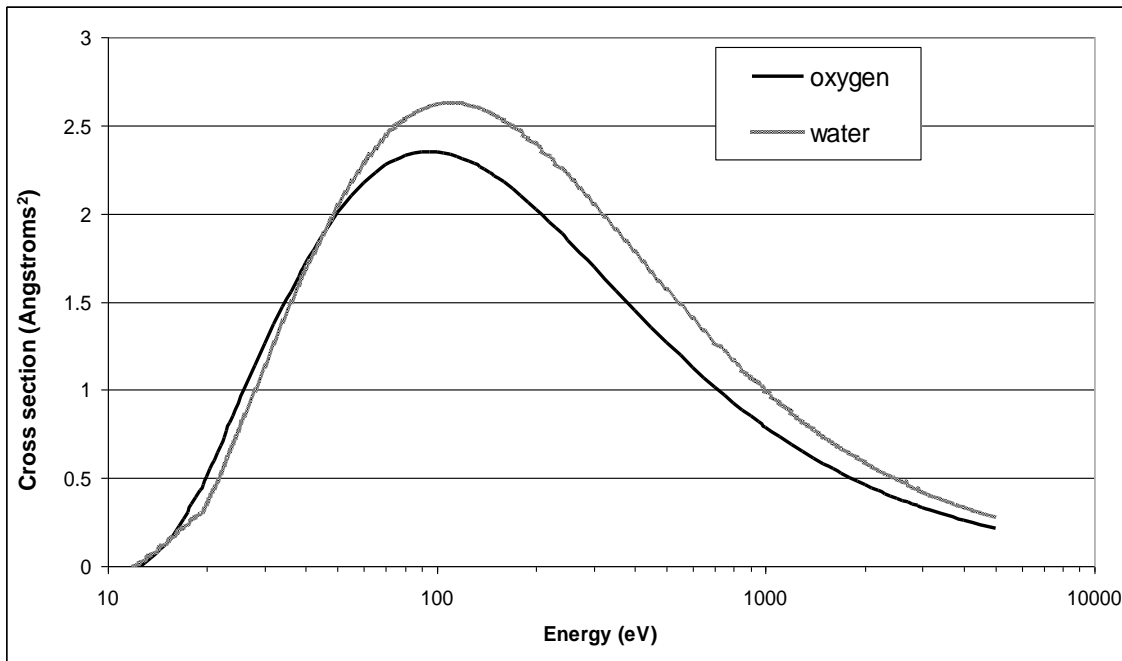

Desorption of Volatile By-Products

By-products not adequately desorbed can be trapped into the deposited structure thus contaminating the deposited material.

Insufficient desorption of volatile etch products can rate limit the etch process by temporarily passivating the near surface region.

By-product desorption can be described by the relationship for the mean stay time (τ_a) in which the residence time is a function of temperature and the by-product desorption activation energy.

An article by Randolph et al. provides a more complete review [S.J. Randolph, J.D. Fowlkes, P.D. Rack, Critical Reviews of Solid State and Materials Sciences, Vol. 31, p. 55-89 (October 2006)].

Xidex

NANODEVICES AT WORK

Monte Carlo Electron Beam Induced Processing Simulation

- Developed by Philip Rack's group (*)
- 3D simulation uses a plural scattering electron-solid Monte Carlo routine to track the primary electron trajectories in the solid substrate.
- Allows for beam to be rastered so effects of beam energy, current density, and scan rates can be simulated.
- Used to design CNT etch experiments.

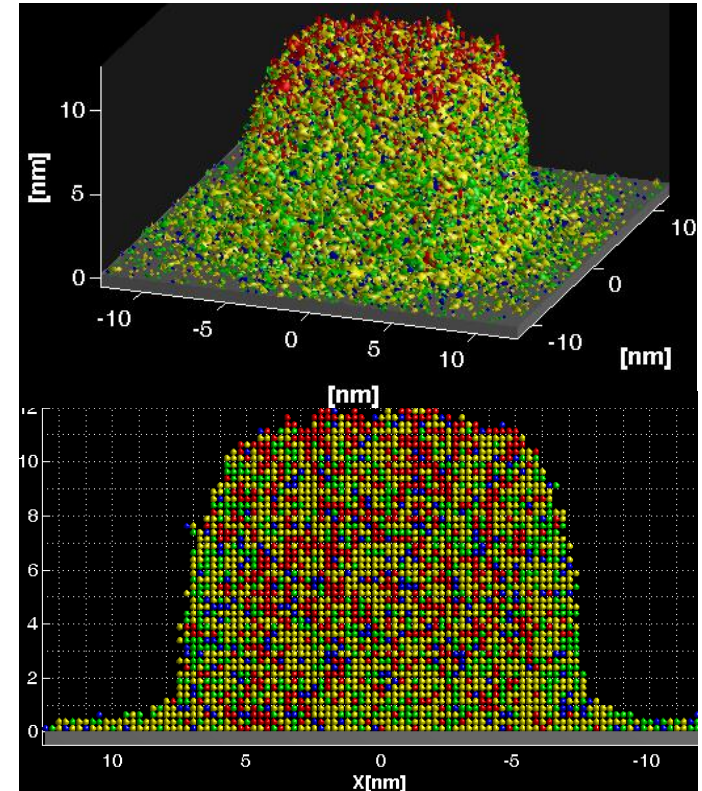

(*) D. Fowlkes, S.J. Randolph, P.D. Rack, Growth and Simulation of High – Aspect Ratio Nanopillars by Primary and Secondary Electron – Induced Deposition Journal of Vacuum Science and Technology B, Microelectronics and Nanometer Structures, Vol 23, no 6, pp 2825-2832 (November/December 2005).

Micro- and Nano-Manipulators

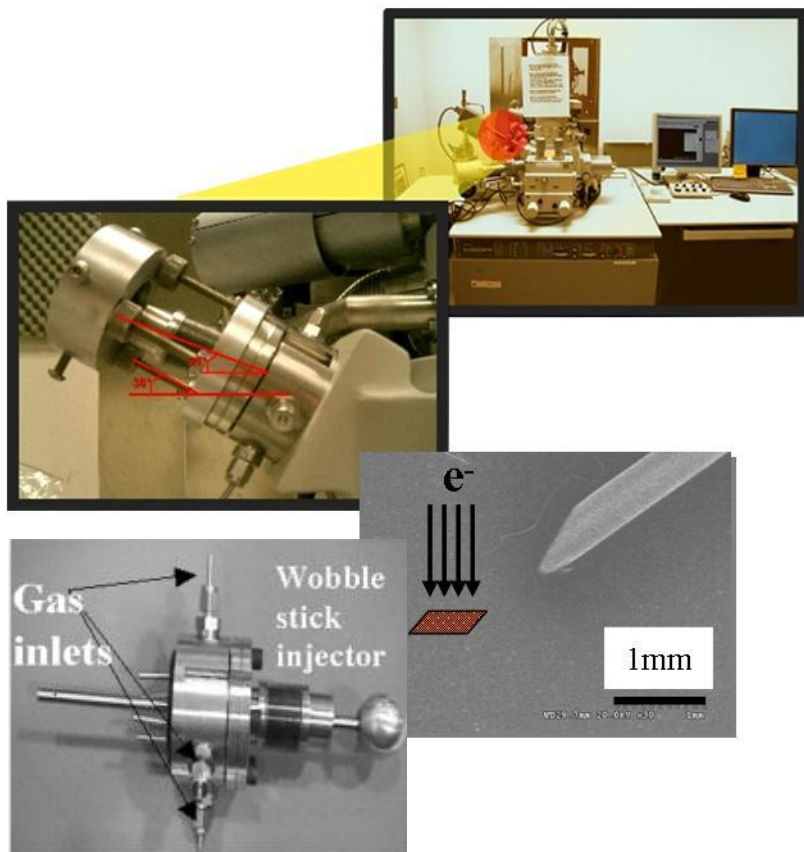

Micromanipulator installed at
The University of Tennessee

Xidex

NANODEVICES AT WORK

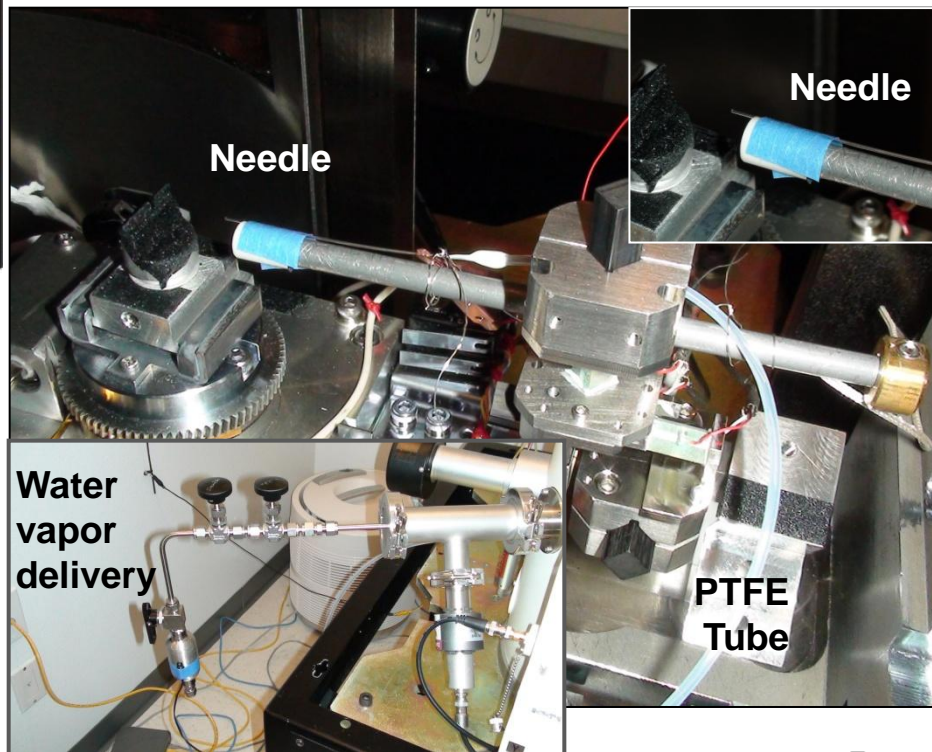

Prototype
Nanomanipulator and
gas delivery system
built by Xidex

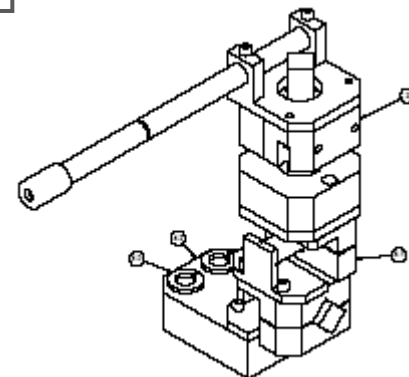

CNT Cleaning

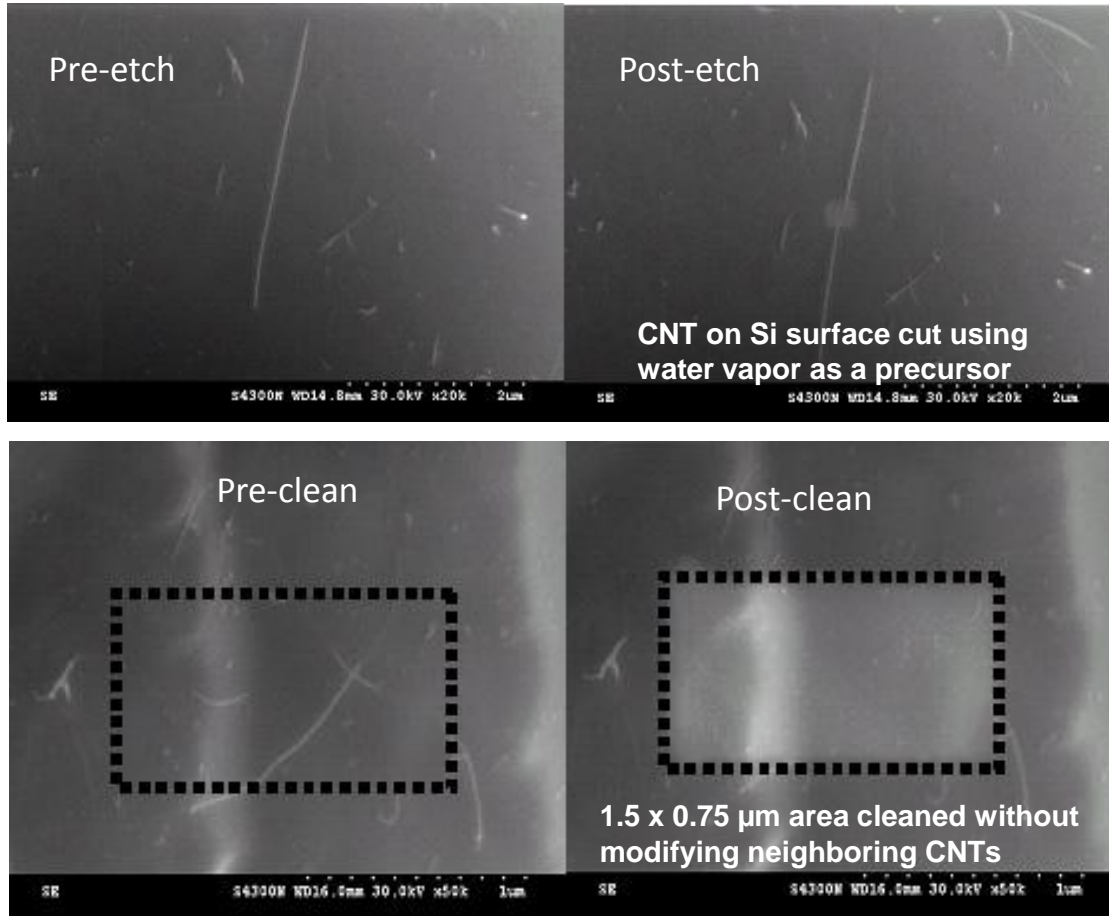

CNTs etching/cleaning using box scan

Xidex

NANODEVICES AT WORK

Cutting of CNTs on Surface

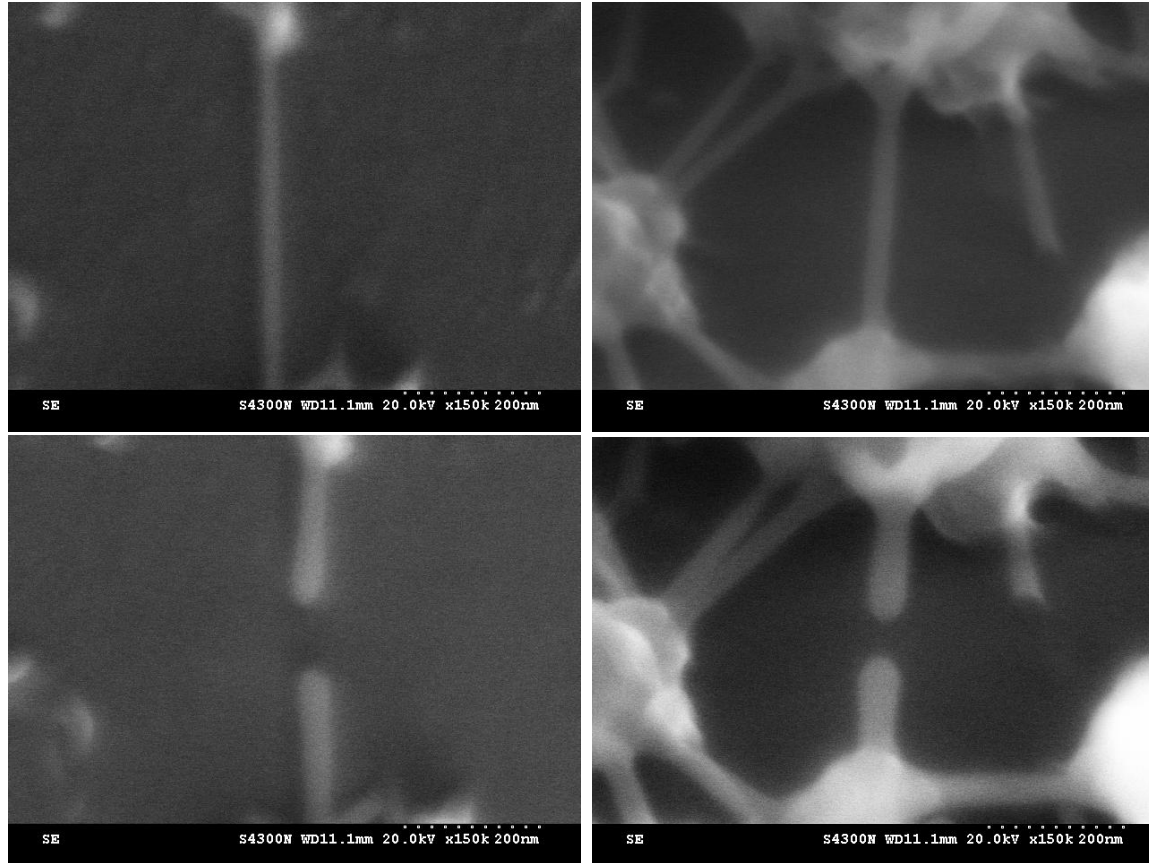

**CNT before (top) and
after cutting (bottom)**

Xidex

NANODEVICES AT WORK

Cutting of CNTs Suspended Above Surface

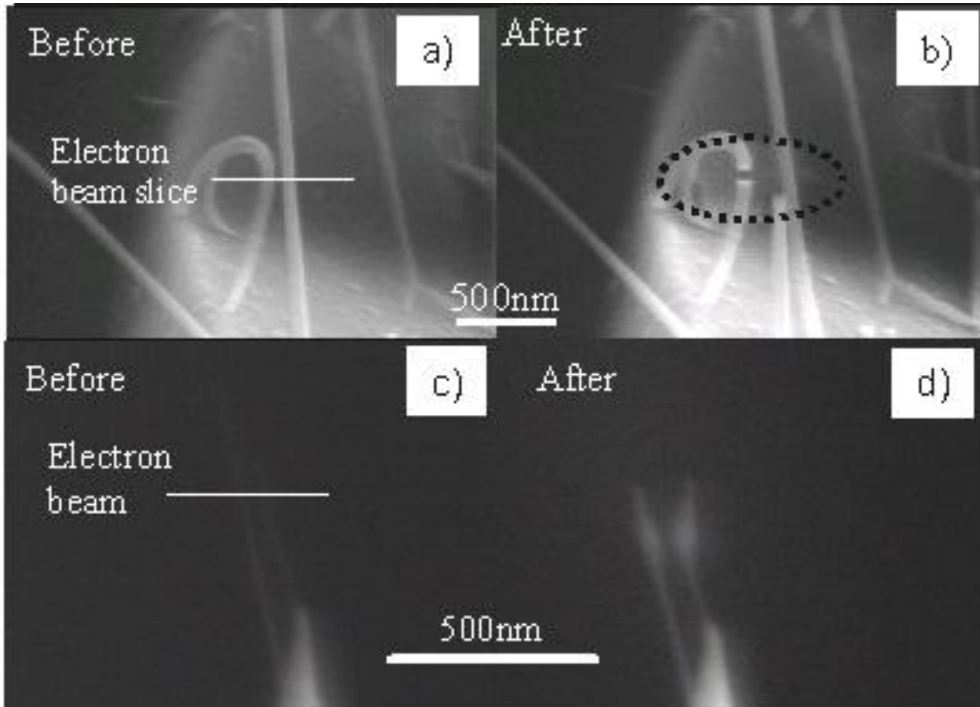

CNT before (left) and after cutting (right)

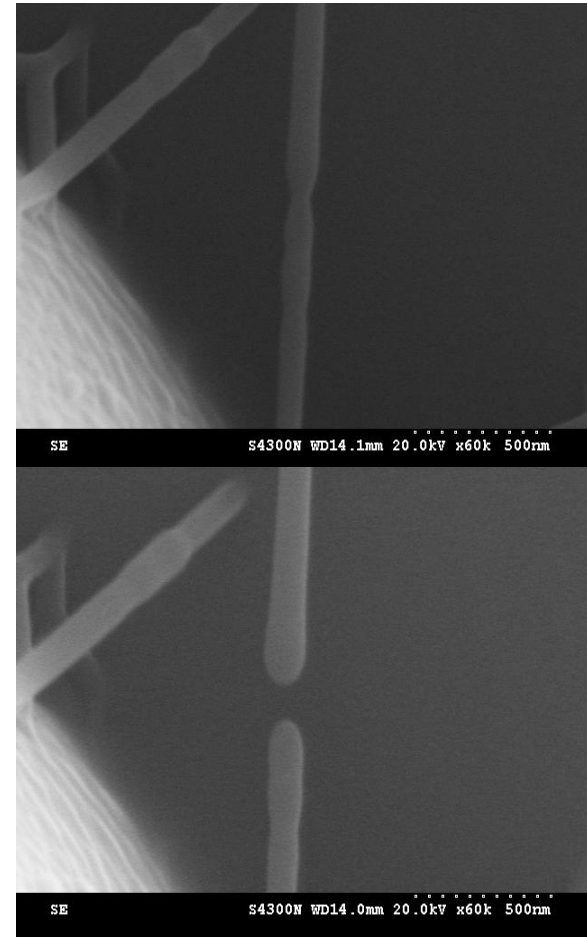

CNT before (top) and after cutting (bottom)

End Point Detection

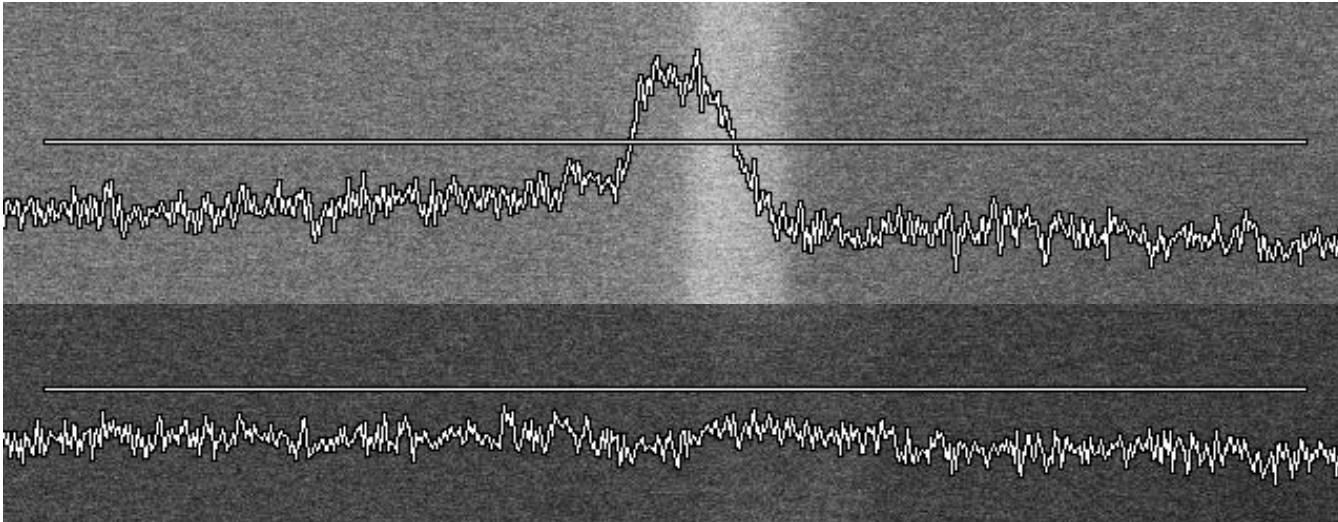

Secondary electron imaging example during line scanning across a CNT (top) and after CNT is cut (bottom)

Xidex

NANODEVICES AT WORK

CNT Cutting Time

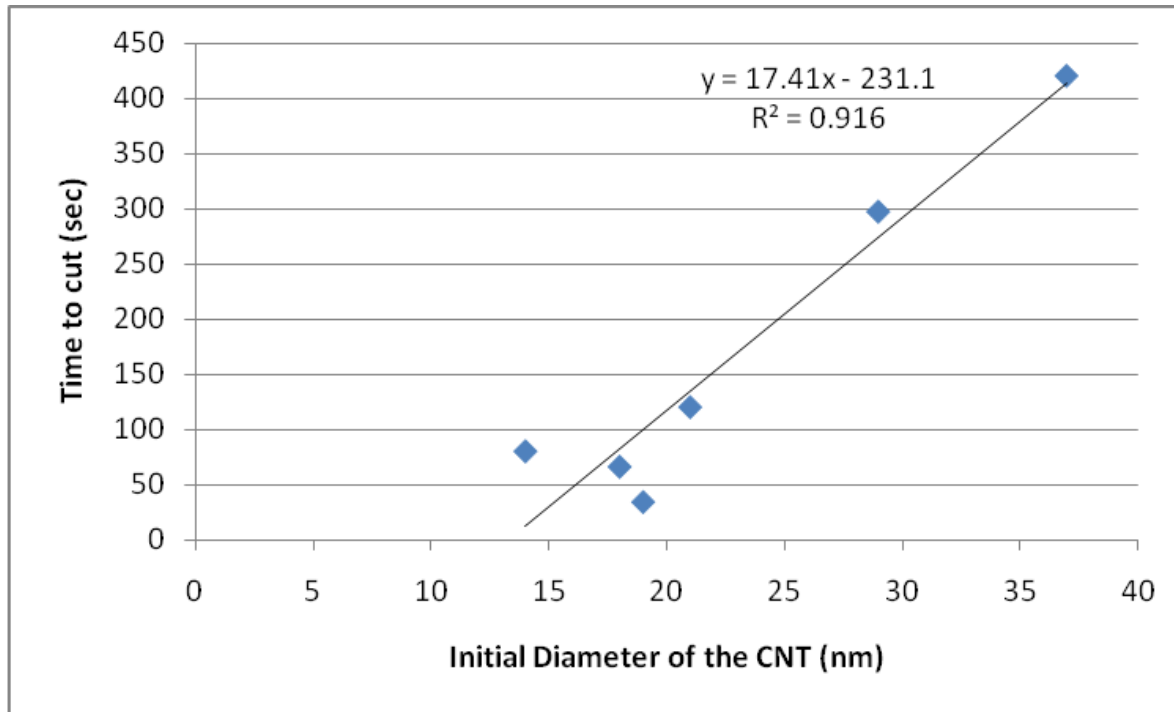

Relationship Between Time to Cut and the Initial Diameter of the CNT

Nanodevice Editing

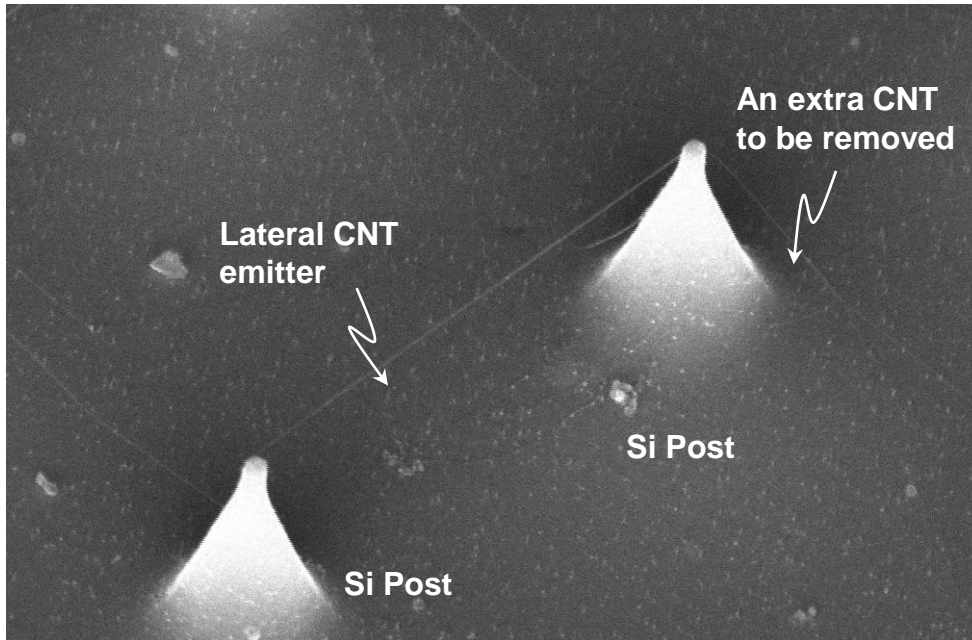

Example of a lateral (horizontal) CNT device fabricated by Xidex for use as a lateral field emitter

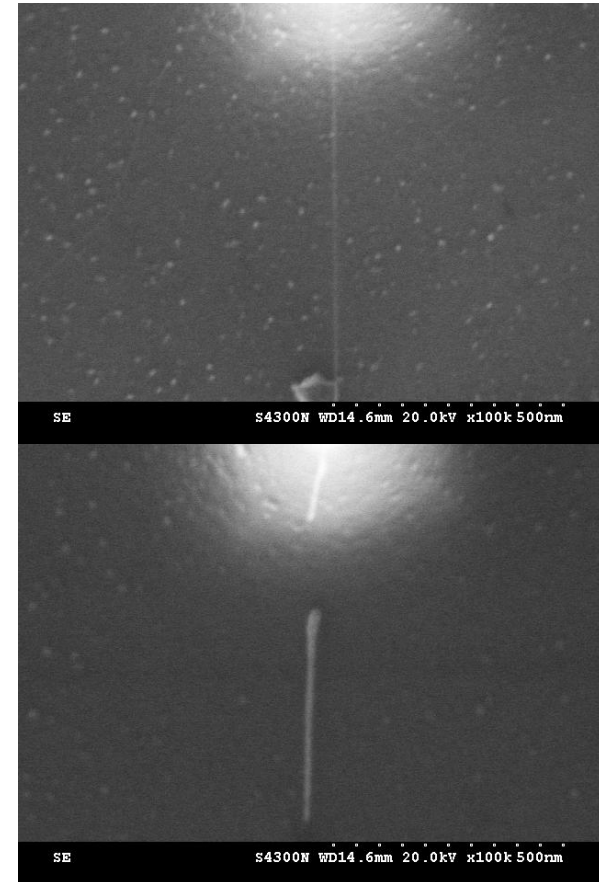

Excess CNT strung from a silicon post (viewed top down) and the surface, before (top) and after (bottom) it was removed using selective CNT etching

Xidex

NANODEVICES AT WORK

CNT Etching/Deposition Factors

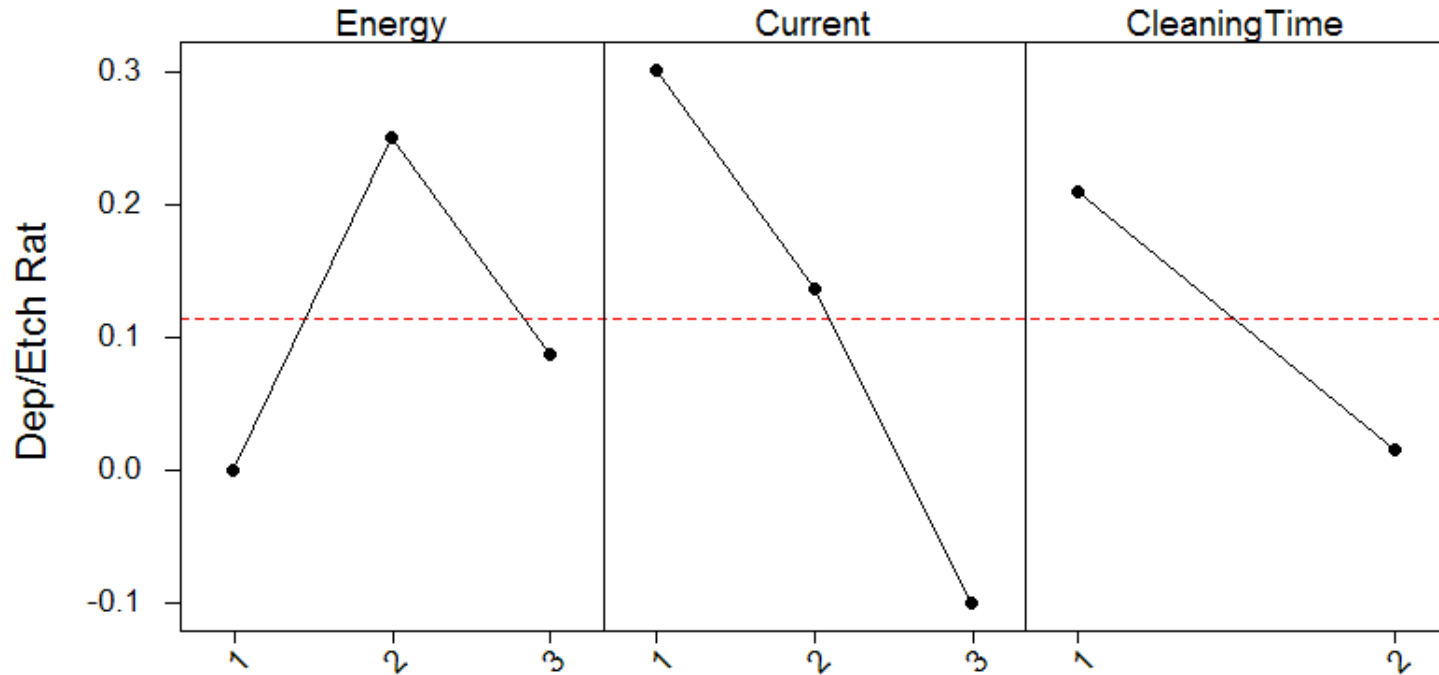

Beam Energy – 5 keV, 12.5 keV, 20 keV

Beam Current – 10 pA, 45 pA, 80 pA

Cleaning Time – 4 min, 20 min

Competitive Carbon Deposition

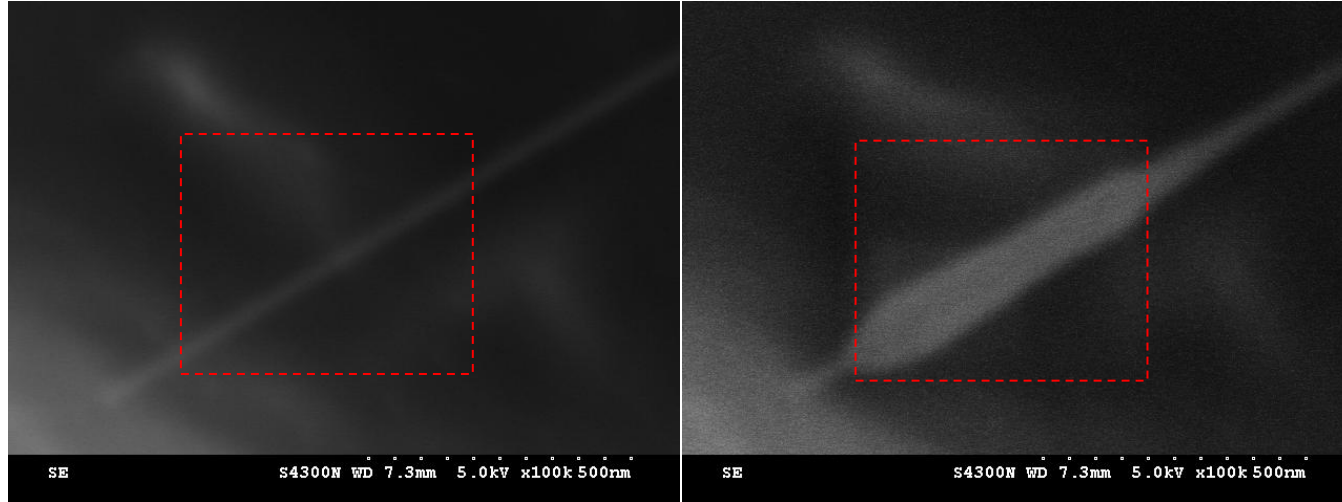

The CNT was imaged by the SEM scanning the region highlighted by the dotted red line. There was significant deposition on the CNT due to carbon contamination in the SEM chamber deposited during exposure to the electron-beam

Plasma Cleaning

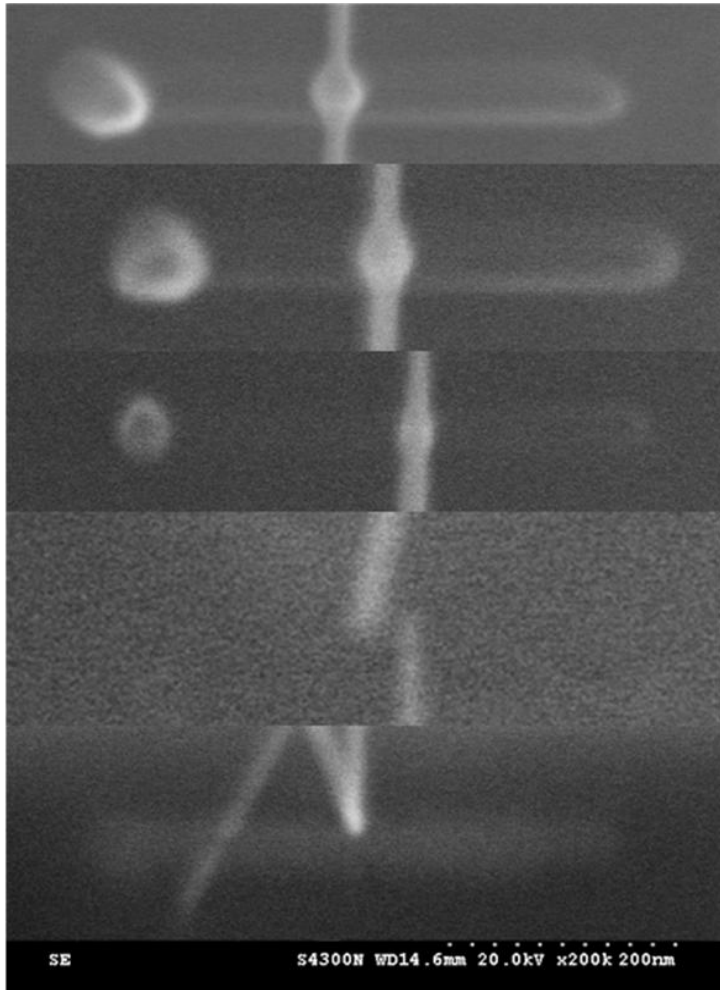

0min EVACTRON (0 flow of H₂O)
+38nm net deposit width on 17nm CNT
120sec process time

0min EVACTRON
+35nm net deposit width
120sec process time

1min EVACTRON
+15nm net deposit width
120sec process time

2min EVACTRON
-17nm net deposit width
90sec process time

4min EVACTRON
-17nm net deposit width
46sec process time

Plasma cleaning can reduce competitive carbon deposition and enhance etching.

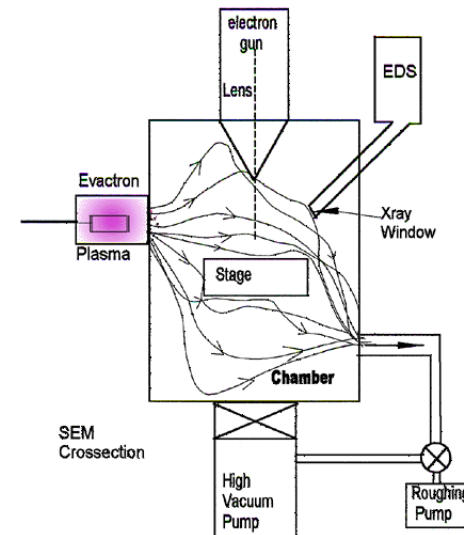

**XEI Scientific EVACTRON™
system schematic**

CNT Etch Rate vs. Beam Current

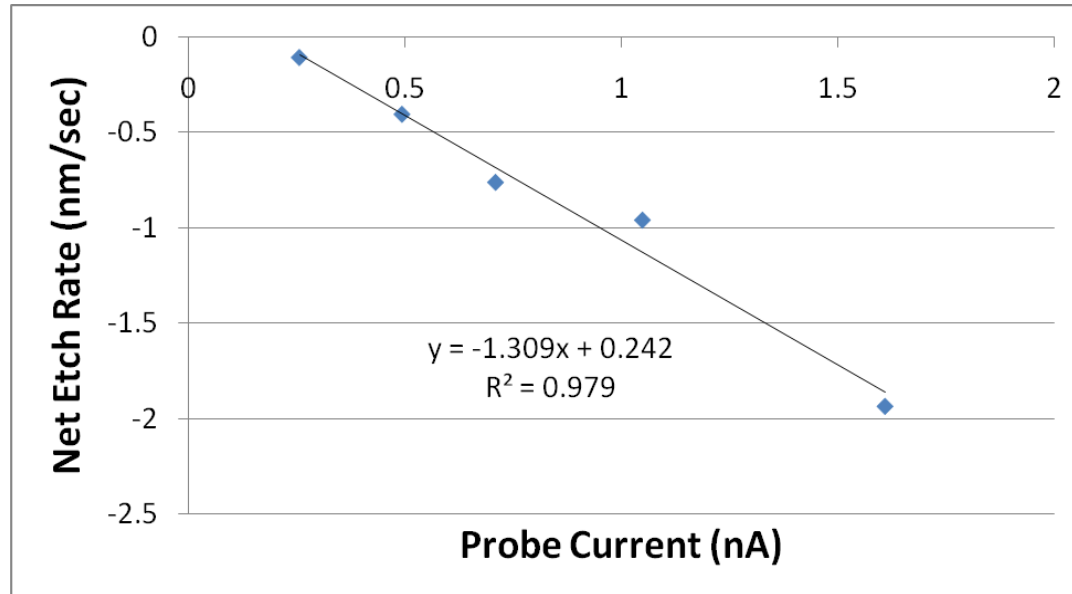

- **Probe size is diffraction limited and therefore the peak electron flux is proportional to the beam current.**
- **The scanning rate is fast enough that the precursor does not deplete during the beam dwell time.**
- **The chamber had been thoroughly cleaned of hydrocarbon contaminants.**
- **The y-axis (net deposit/etch rate) intercept is positive, indicating that there is a competitive deposition process that would dominate at low beam currents.**
- **Etch rate improves with increasing probe current.**

Increasing the Beam Current Has Its Limitations

- Increasing the convergence angle will increase the electron flux in a perfect lens.
- However, realistically, spherical aberration increases with increasing convergence angle and provides an upper limit to the electron flux.
- Increasing the beam current by passing more current through the limiting aperture with the condenser lens makes the probe shape become brightness limited.
- Further increases to current do not increase the peak electron flux, but rather the width of the beam.

High Localized Pressure as an Alternative to High Beam Current

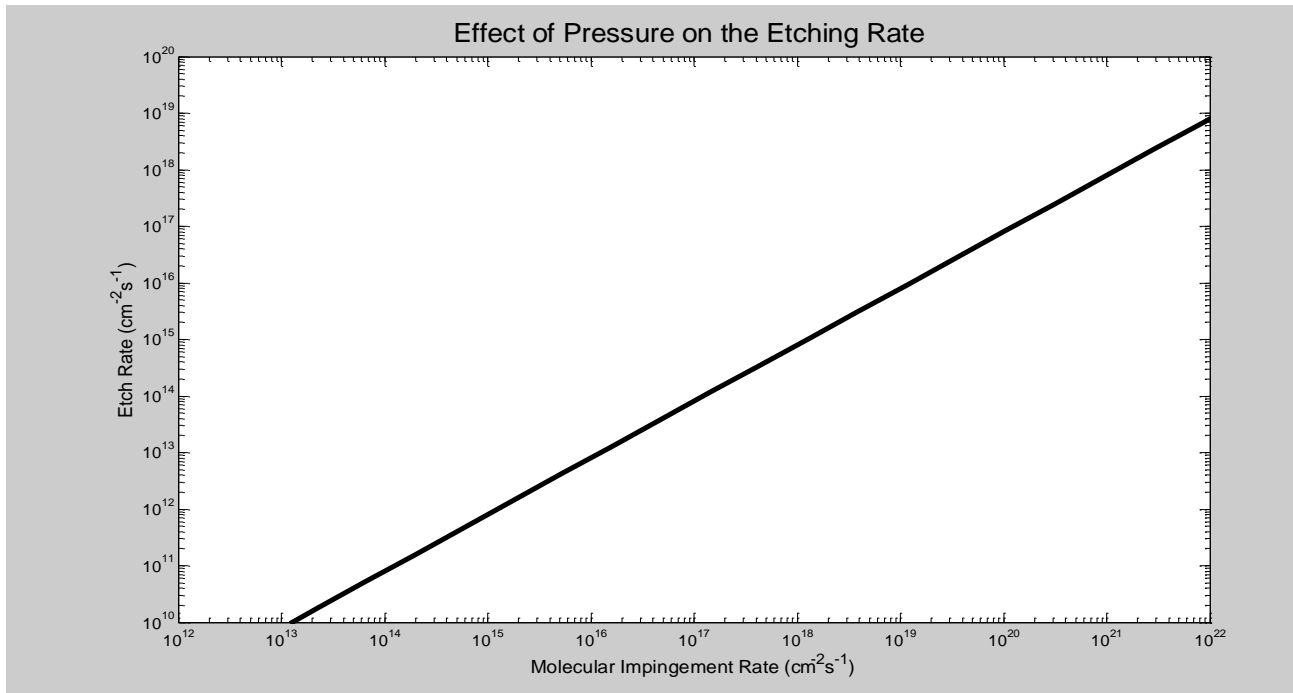

- As the pressure increases, the etch rate increases as well due to the higher coverage of water precursor on the surface.
- It would be desirable to design a system that operates at a higher localized pressure in order to increase the gas coverage of water and thus increase the etching rate.

Achieving High Local Pressure in a Non-Environmental SEM



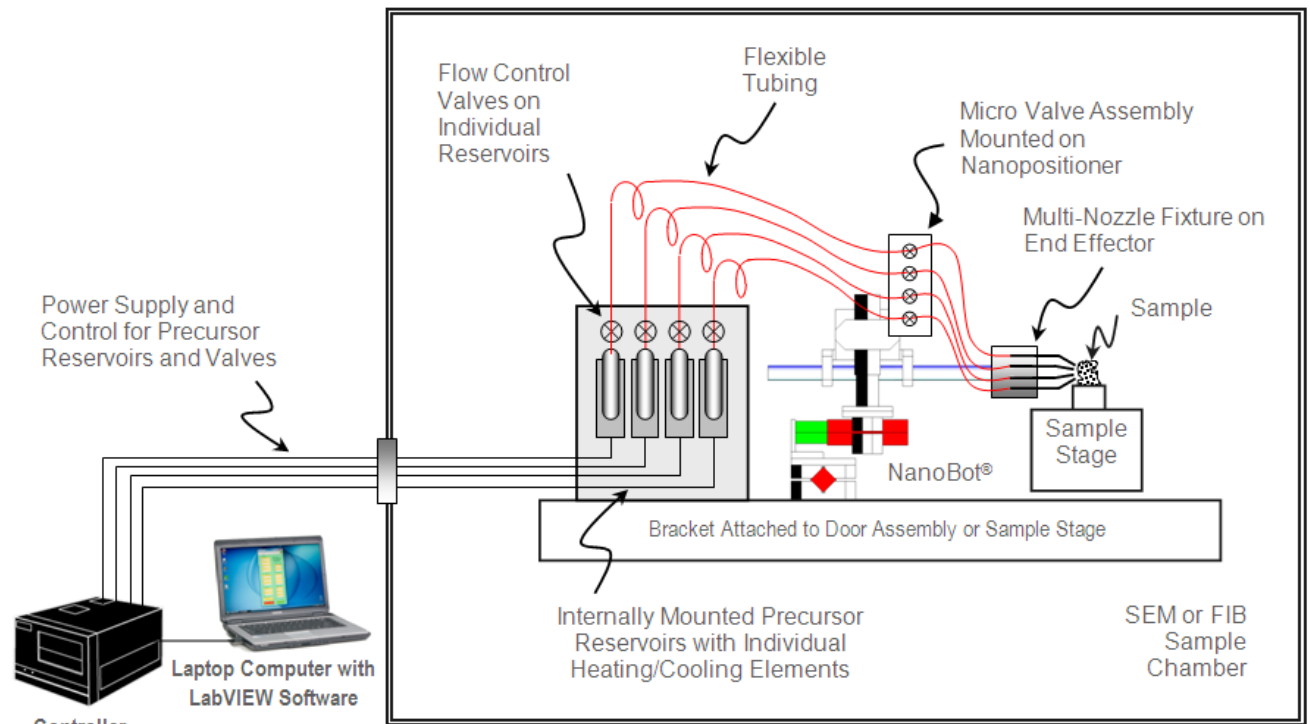

- Fixing gas delivery nozzles to a precision XYZ nanomanipulator allows the nozzles to be positioned 10s of microns away from the sample.
- The resulting localized pressure can be two or three orders of magnitude higher than the background pressure, enabling E-beam induced etching and deposition in in a non-environmental SEM.

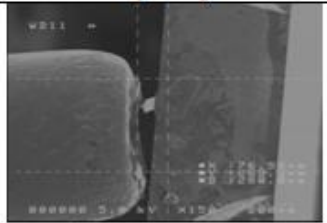
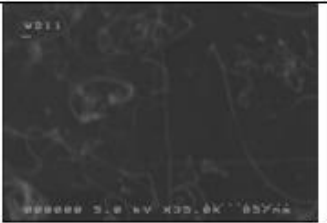
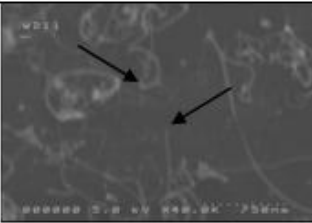
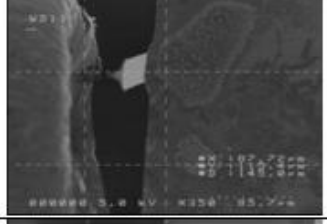
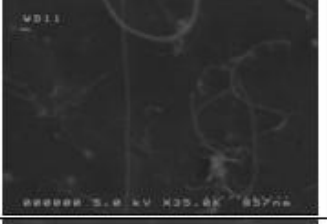
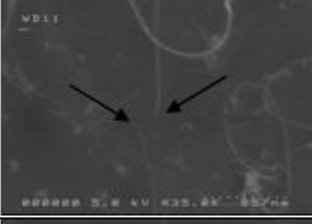

Precise Nozzle Positioning

A gas delivery system fixed to a nanomanipulator allows precise positioning of the gas nozzle with respect to the sample in a range of 50 μm to 1000 μm .

The resulting nozzle proximity results in improved CNT etching capabilities.

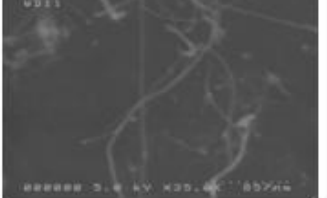
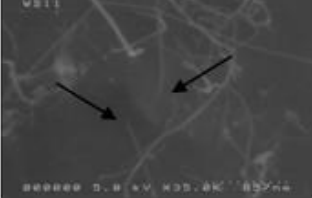
Gap(μ)	Gap Image	CNT Before Cut	CNT After Cut
76			
87			
164			
328			

Improved CNT Etching Time vs. Nozzle-Sample Gap

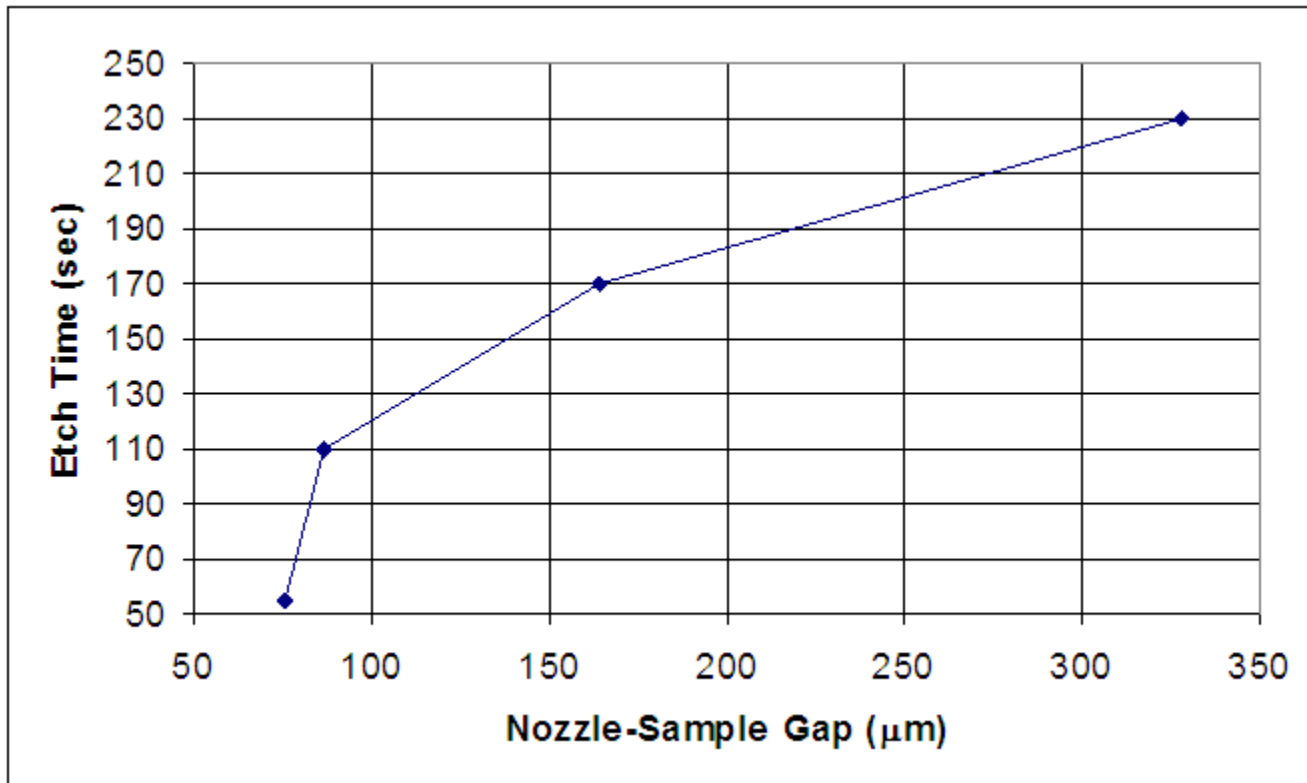

Localized Pressure Enhancement Above Background Pressure

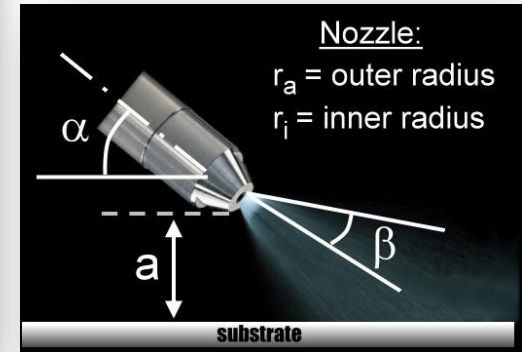
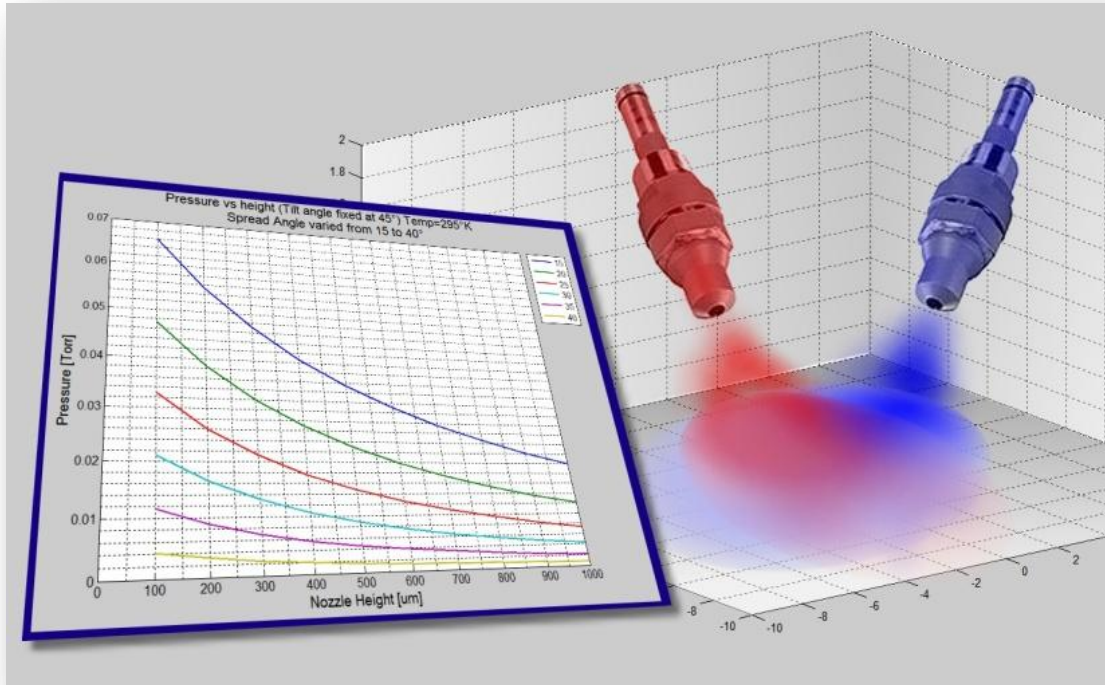

To estimate the localized pressure/flux from the nozzle, a simulation was used that was initially developed by Kohlmann et al. [Kohlmann, K., Thiemann, M. and Bringer, W. E-beam induced X-ray mask repair with optimized gas nozzle geometry. *Microelectronic Engineering* 13 (1991), 279.]

Multi-Precursor Parallel Gas Delivery Using NanoBot[®]

The Xidex Gas Precursor Delivery System is integrated with Xidex's NanoBot nanomanipulator to enable precise interaction with micro- and nano-scale objects.

The system accommodates up to four different gasses which are delivered via separate tubes and mix at the sample surface.

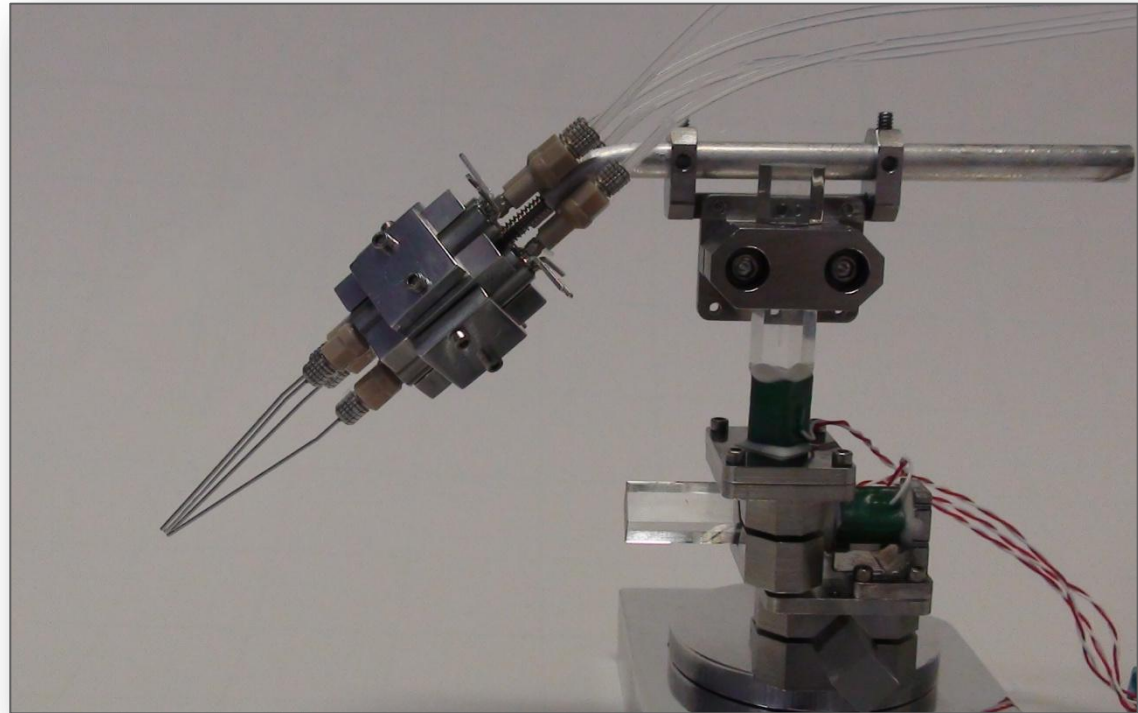

Xidex

NANODEVICES AT WORK

CONCLUSIONS

1. Damage-free, site-selective vapor phase cutting of CNTs is important tool for the nanotechnology.
2. CNT etching rate depends on the electron beam energy, electron beam current, and chamber cleanliness.
3. CNT etching rate improves dramatically at small nozzle-sample distance.
4. Using a nanomanipulator enables small nozzle-sample distances resulting in optimal localized precursor pressure and flux at reduced chamber pressures.
5. Use of separate delivery tubes for each gas precludes contamination from residual traces of previously used process gas and enables fast switching between multiple gasses without having to wait to purge the previous gas.

ACKNOWLEDGEMENTS

NSF - “Selective Carbon Nanotube Etching,” National Science Foundation Phase I STTR project, Award # IIP-0712036, July 2007-December 2008.

SEMATECH - “Conductive Carbon Nanotube AFM Tips for Scanning Probe Microscopy Applications,” The Research Foundation of State University of New York and SEMATECH, Inc., Project #MFGM049M-N2, September 2009-June 2010.